

LM92

$\pm 0.33^{\circ}\text{C}$ Accurate, 12-Bit + Sign Temperature Sensor and Thermal Window Comparator with Two-Wire Interface

General Description

The LM92 is a digital temperature sensor and thermal window comparator with an I²C™ Serial Bus interface and an accuracy of $\pm 0.33^{\circ}\text{C}$. The window-comparator architecture of the LM92 eases the design of temperature control systems. The open-drain Interrupt (INT) output becomes active whenever temperature goes outside a programmable window, while a separate Critical Temperature Alarm (T_CRIT_A) output becomes active when the temperature exceeds a programmable critical limit. The INT output can operate in either a comparator or event mode, while the T_CRIT_A output operates in comparator mode only.

The host can program both the upper and lower limits of the window as well as the critical temperature limit. Programmable hysteresis as well as a fault queue are available to minimize false tripping. Two pins (A0, A1) are available for address selection. The sensor powers up with default thresholds of 2°C T_{HYST}, 10°C T_{LOW}, 64°C T_{HIGH}, and 80°C T_{CRIT}.

The LM92's 2.7V to 5.5V supply voltage range, Serial Bus interface, 12-bit + sign output, and full-scale range of over 128°C make it ideal for a wide range of applications. These include thermal management and protection applications in personal computers, electronic test equipment, office electronics, automotive, medical and HVAC applications.

Features

- Window comparison simplifies design of ACPI compatible temperature monitoring and control.
- Serial Bus interface
- Separate open-drain outputs for Interrupt and Critical Temperature shutdown

- Shutdown mode to minimize power consumption
- Up to 4 LM92s can be connected to a single bus
- 12-bit + sign output
- Operation up to 150°C

Key Specifications

■ Supply Voltage		2.7V to 5.5V
■ Supply Current	operating	350 μA (typ) 625 μA (max)
	shutdown	5 μA (typ)
■ Temperature	30°C	$\pm 0.33^{\circ}\text{C}$ (max)
■ Accuracy	10°C to 50°C	$\pm 0.50^{\circ}\text{C}$ (max)
	-10°C to 85°C	$\pm 1.0^{\circ}\text{C}$ (max)
	125°C	$\pm 1.25^{\circ}\text{C}$ (max)
	-25°C to 150°C	$\pm 1.5^{\circ}\text{C}$ (max)
■ Linearity		$\pm 0.5^{\circ}\text{C}$ (max)
■ Resolution		0.0625 $^{\circ}\text{C}$

Applications

- HVAC
- Medical Electronics
- Electronic Test Equipment
- System Thermal Management
- Personal Computers
- Office Electronics
- Automotive

Simplified Block Diagram

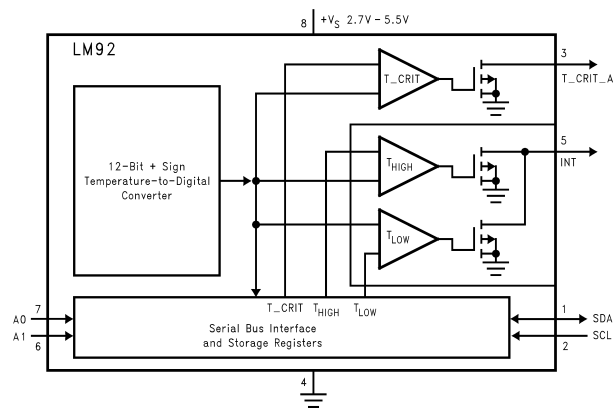

DS101051-1

I²C® is a registered trademark of Philips Corporation.

Connection Diagram

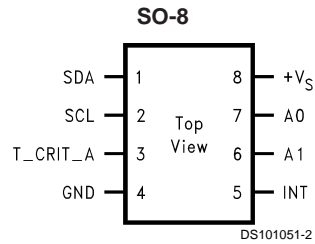

Ordering Information

Order Number	Supply Voltage	Supplied As
LM92CIM	2.7V to 5.5V	
LM92CIMX	2.7V to 5.5V	2500 Units on Tape and Reel

Pin Descriptions

Label	Pin #	Function	Typical Connection
SDA	1	Serial Bi-Directional Data Line. Open Drain Output	From Controller
SCL	2	Serial Bus Clock Input	From Controller
T_CRIT_A	3	Critical Temperature Alarm Open Drain Output	Pull Up Resistor, Controller Interrupt Line or System Hardware Shutdown
GND	4	Power Supply Ground	Ground
INT	5	Interrupt Open Drain Output	Pull Up Resistor, Controller Interrupt Line
+V _S	8	Positive Supply Voltage Input	DC Voltage from 2.7V to 5.5V
A0–A1	7,6	User-Set Address Inputs	Ground (Low, "0") or +V _S (High, "1")

Typical Application

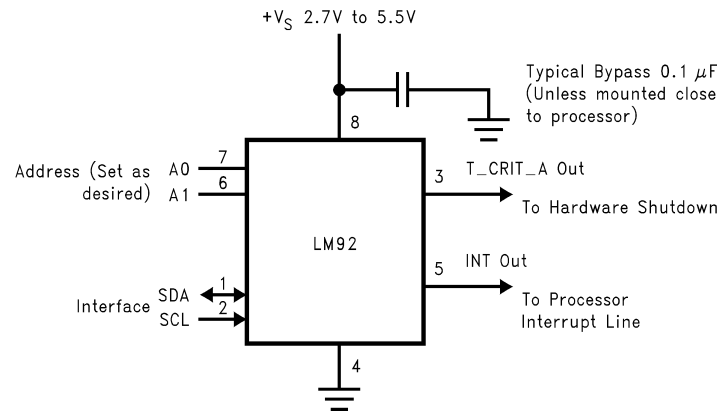

Absolute Maximum Ratings (Note 1)

Supply Voltage	-0.3 V to 6.5V
Voltage at any Pin	-0.3 V to (+V _S + 0.3V)
Input Current at any Pin	5mA
Package Input Current (Note 2)	20mA
T_CRIT_A and INT Output Sink Current	10mA
T_CRIT_A and INT Output Voltage	6.5V
Storage Temperature	-65°C to +125°C

Soldering Information, Lead Temperature

SOP and MSOP Package (Note 3)

Vapor Phase (60 seconds)	215°C
Infrared (15 seconds)	220°C
ESD Susceptibility (Note 4)	
Human Body Model	2500V
Machine Model	250V

Operating Ratings(Notes 1, 5)

Specified Temperature Range (Note 6)	T _{MIN} to T _{MAX} -55°C to +150°C
Supply Voltage Range (+V _S)	+2.7V to +5.5V

Electrical Characteristics

Temperature-to-Digital Converter Characteristics Unless otherwise noted, these specifications apply for +V_S=+2.7V to +5.5V for LM92CIM. **Boldface limits apply for T_A = T_J = T_{MIN} to T_{MAX}**; all other limits T_A= T_J=+25°C, unless otherwise noted.

Parameter	Conditions	Typical (Note 7)	Limits (Note 8)	Units (Limit)
Accuracy (This is a summary. For more detailed information please see (Note 9))	T _A = +30°C, +V _S = 3.3V to 4.0V		±0.33	°C (max)
	T _A = 10°C or +50°C, +V _S = 3.3V to 4.0V		±0.50	
	T _A = -10°C or +85°C, +V _S = 3.3V to 4.0V		±1.00	
	T _A = +125°C, +V _S = 4.0V		±1.25	
	T _A = -25°C to 150°C, +V _S = 4.0V		±1.50	
Resolution	(Note 10)	13 0.0625		Bits °C
Linearity (Note 11)			±0.5	°C (max)
Offset Error of Transfer Function (Note 12)	+V _S = 4.0V			°C (max)
Offset Error of Transfer Function Supply Sensitivity	2.7V ≤ +V _S < 3.6V			°C/V (max)
	3.6V ≤ +V _S ≤ 5.5V			°C/V (max)
Temperature Conversion Time	(Note 13)	500	1000	ms
Quiescent Current	I ² C Inactive	0.35	0.625	mA
	I ² C Active	0.35		mA (max)
	Shutdown Mode	5		μA
T _{HYST} Default Temperature	(Notes 15, 16)	2		°C
T _{LOW} Default Temperature	(Note 16)	10		°C
T _{HIGH} Default Temperature	(Note 16)	64		°C
T _C Default Temperature	(Note 16)	80		°C

Electrical Characteristics

DIGITAL DC CHARACTERISTICS Unless otherwise noted, these specifications apply for $+V_S=+2.7V$ to $+5.5V$ for LM92CIM. **Boldface limits apply for $T_A = T_J = T_{MIN}$ to T_{MAX}** ; all other limits $T_A = T_J = +25^\circ C$, unless otherwise noted.

Symbol	Parameter	Conditions	Typical (Note 7)	Limits (Note 8)	Units (Limit)
$V_{IN(1)}$	SDA and SCL Logical "1" Input Voltage			$+V_S \times 0.7$ $+V_S+0.3$	V (min) V (max)
$V_{IN(0)}$	SDA and SCL Logical "0" Input Voltage			-0.3 $+V_S \times 0.3$	V (min) V (max)
$V_{IN(HYST)}$	SDA and SCL Digital Input Hysteresis		500	250	mV (min)
$V_{IN(1)}$	A0 and A1 Logical "1" Input Voltage			2.0 $+V_S+0.3$	V (min) V (max)
$V_{IN(0)}$	A0 and A1 Logical "0" Input Voltage			-0.3 0.7	V (min) V (max)
$I_{IN(1)}$	Logical "1" Input Current	$V_{IN} = +V_S$	0.005	1.0	μA (max)
$I_{IN(0)}$	Logical "0" Input Current	$V_{IN} = 0 V$	-0.005	-1.0	μA (max)
C_{IN}	Capacitance of All Digital Inputs		20		pF
I_{OH}	High Level Output Current	$V_{OH} = +V_S$		10	μA (max)
V_{OL}	Low Level Output Voltage	$I_{OL} = 3 mA$		0.4	V (max)
	T_CRIT_A Output Saturation Voltage	$I_{OUT} = 4.0 mA$ (Note 14)		0.8	V (max)
	T_CRIT_A Delay			1	Conversions (max)
t_{OF}	Output Fall Time	$C_L = 400 pF$ $I_O = 3 mA$		250	ns (max)

SERIAL BUS DIGITAL SWITCHING CHARACTERISTICS Unless otherwise noted, these specifications apply for $+V_S=+2.7V$ to $+5.5V$ for LM92CIM. **Boldface limits apply for $T_A = T_J = T_{MIN}$ to T_{MAX}** ; all other limits $T_A = T_J = +25^\circ C$, unless otherwise noted. C_L (load capacitance) on output lines = 80 pF unless otherwise specified. **Boldface limits apply for $T_A = T_J = T_{MIN}$ to T_{MAX}** ; all other limits $T_A = T_J = +25^\circ C$, unless otherwise noted.

The switching characteristics of the LM92 fully meet or exceed the published specifications of the I²C bus. The following parameters are the timing relationship between SCL and SDA signal related to the LM92. They are not the I²C bus specifications.

Symbol	Parameter	Conditions	Typical (Note 7)	Limits (Note 8)	Units (Limit)
t_1	SCL (Clock) Period			2.5	μs (min)
				1	ms(max)
t_2	Data in Set-Up Time to SCL High			100	ns(min)
t_3	Data Out Stable after SCL Low			0	ns(min)
t_4	SDA Low Set-Up Time to SCL Low (Start Condition)			100	ns(min)
t_5	SDA High Hold Time after SCL High (Stop Condition)			100	ns(min)
$t_{TIMEOUT}$	SDA and SCL Time Low for Reset of Serial Interface (Note 17)			75	ms (min)
				300	ms (max)

Electrical Characteristics (Continued)

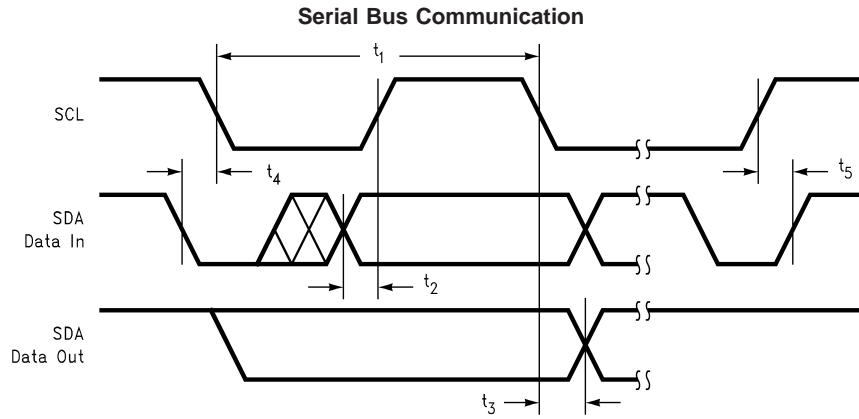

Note 1: Absolute Maximum Ratings indicate limits beyond which damage to the device may occur. DC and AC electrical specifications do not apply when operating the device beyond its rated operating conditions.

Note 2: When the input voltage (V_I) at any pin exceeds the power supplies ($V_I < \text{GND}$ or $V_I > +V_S$) the current at that pin should be limited to 5 mA. The 20 mA maximum package input current rating limits the number of pins that can safely exceed the power supplies with an input current of 5 mA to four.

Note 3: See AN-450 "Surface Mounting Methods and Their Effect on Product Reliability" or the section titled "Surface Mount" found in a current National Semiconductor Linear Data Book for other methods of soldering surface mount devices.

Note 4: Human body model, 100 pF discharged through a 1.5 k Ω resistor. Machine model, 200 pF discharged directly into each pin.

Note 5: LM92 θ_{JA} (thermal resistance, junction-to-ambient) when attached to a printed circuit board with 2 oz. foil is 200 °C/W.

Note 6: While the LM92 has a full-scale-range in excess of 128 °C, prolonged operation at temperatures above 125 °C is not recommended.

Note 7: Typicals are at $T_A = 25$ °C and represent most likely parametric norm.

Note 8: Limits are guaranteed to National's AOQL (Average Outgoing Quality Level).

Electrical Characteristics (Continued)

Note 9: The limits found in the following table supersede the limits shown in the Electrical Characteristics Table. The Accuracy specification includes errors due to linearity, offset and gain. The accuracy specification includes effects of self heating with negligible digital output loading. Pull-up resistors should be maximized (10k typical recommended), so that self heating due to digital output loading is negligible.

Conditions	Temperature Accuracy Parameter Limits					Units
	+V _S =2.7V	+V _S =3.3V	+V _S =4V	+V _S =5V	+V _S =5.5V	
T _A = -25°C	-1.35/+1.50	-1.25/+1.50	-1.25/+1.50	-1.05/+1.70	-1.05/+1.80	°C (max)
T _A = -10°C	±1.00	-0.90/+1.00	-0.90/+1.00	-0.70/+1.20	-0.70/+1.30	°C (max)
T _A = 0°C	-0.80/+0.75	-0.70/+0.75	-0.70/+0.75	-0.50/+0.95	-0.50/+1.05	°C (max)
T _A = 10°C	-0.60/+0.50	±0.50	±0.50	-0.30/+0.70	-0.30/+0.80	°C (max)
T _A = 30°C	-0.43/+0.33	±0.33	±0.33	-0.13/+0.53	-0.13/+0.63	°C (max)
T _A = 50°C	-0.60/+0.50	±0.50	±0.50	-0.30/+0.70	-0.30/+0.80	°C (max)
T _A = 85°C	-1.10/+0.85	-1.00/+0.85	-1.00/+0.85	-0.80/+1.05	-0.80/+1.15	°C (max)
T _A = 125°C	-1.60/+1.25	-1.50/+1.25	±1.25	-1.05/+1.45	-1.05/+1.55	°C (max)
T _A = 150°C	±1.90	-1.75/+1.50	±1.50	-1.30/+1.70	-1.30/+1.80	°C (max)

Limits at intermediate temperatures can be calculated using a straight line interpolation as shown in the following graphs:

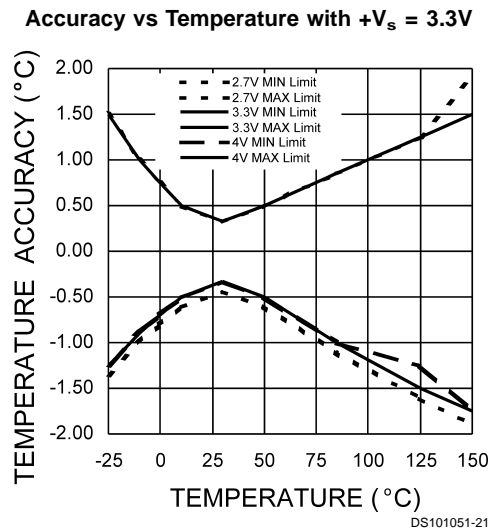
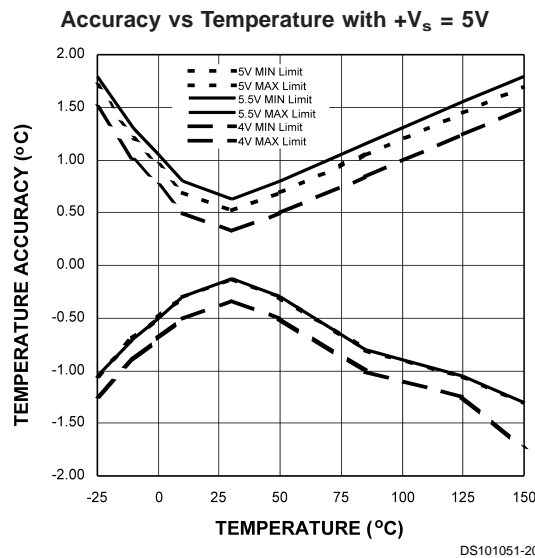

Note 10: 12 bits + sign, two's complement

Electrical Characteristics (Continued)

Note 11: Linearity Error is defined as the worse case difference of an actual reading to that of a calculated reading derived from the straight line whose endpoints are measured at 30°C and 125°C for the range of 30°C to 125°C or whose endpoints are measured at 30°C and -25°C for the range of 30°C to -25°C.

Note 12: Offset Error calibration should be done at 30°C. The residual error of the transfer function is then equivalent to the Accuracy Limit minus the Offset Limit. This does not take into account the power supply sensitivity of the offset error. Nor, does it take into account the error introduced by the calibration system used.

Note 13: This specification is provided only to indicate how often temperature data is updated. The LM92 can be read at any time without regard to conversion state (and will yield last conversion result). If a conversion is in process it will be interrupted and restarted after the end of the read.

Note 14: For best accuracy, minimize output loading. 10k pull-ups resistors should be sufficient. Higher sink currents can affect sensor accuracy with internal heating. This can cause an error of 0.64 °C at full rated sink current and saturation voltage based on junction-to-ambient thermal resistance.

Note 15: Hysteresis value adds to the T_{LOW} setpoint value (e.g.: if T_{LOW} setpoint = 10 °C, and hysteresis = 2 °C, then actual hysteresis point is 10+2 = 12 °C); and subtracts from the T_{HIGH} and T_{CRIT} setpoints (e.g.: if T_{HIGH} setpoint = 64 °C, and hysteresis = 2 °C, then actual hysteresis point is 64-2 = 62 °C). For a detailed discussion of the function of hysteresis refer to *Section 1.1, TEMPERATURE COMPARISON, and Figure 3.*

Note 16: Default values set at power up.

Note 17: Holding the SDA and/or SCL lines Low for a time interval greater than $t_{TIMEOUT}$ will cause the LM92 to reset SCL and SDA to the IDLE state of the serial bus communication (SDA and SCL set High).

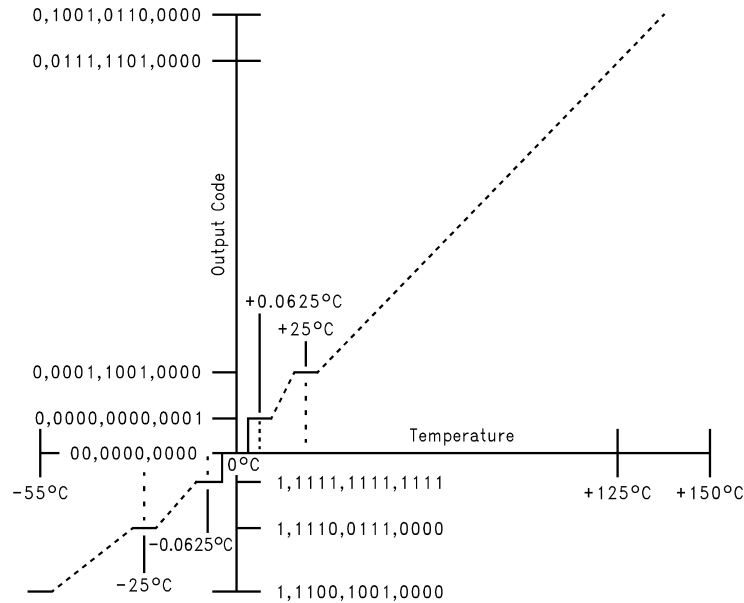

DS101051-5

FIGURE 2. Temperature-to-Digital Transfer Function (Non-linear scale for clarity)

1.0 Functional Description

The LM92 temperature sensor incorporates a band-gap type temperature sensor, 13-bit ADC, and a digital comparator with user-programmable upper and lower limit values. The comparator activates either the INT line for temperatures outside the T_{LOW} and T_{HIGH} window, or the T_CRIT_A line for temperatures which exceed T_CRIT . The lines are programmable for mode and polarity.

1.1 TEMPERATURE COMPARISON

LM92 provides a window comparison against a lower (T_{LOW}) and upper (T_{HIGH}) trip point. A second upper trip point (T_CRIT) functions as a critical alarm shutdown. *Figure 3* depicts the comparison function as well as the modes of operation.

1.1.1 STATUS BITS

The internal Status bits operate as follows:

“True”: Temperature above a T_{HIGH} or T_CRIT is “true” for those respective bits. A “true” for T_{LOW} is temperature below T_{LOW} .

“False”: Assuming temperature has previously crossed above T_{HIGH} or T_CRIT , then the temperature must drop below the points corresponding T_{HYST} ($T_{HIGH} - T_{HYST}$ or $T_CRIT - T_{HYST}$) in order for the condition to be false. For T_{LOW} , assuming temperature has previously crossed below T_{LOW} , a “false” occurs when temperature goes above $T_{LOW} + T_{HYST}$.

The Status bits are not affected by reads or any other actions, and always represent the state of temperature vs. setpoints.

1.1.2 HARDWIRE OUTPUTS

The T_CRIT_A hardwire output mirrors the T_CRIT_A flag, when the flag is true, the T_CRIT_A output is asserted at all times regardless of mode. Reading the LM92 has no effect on the T_CRIT_A output, although the internal conversion is restarted.

The behavior of the INT hardwire output is as follows:

Comparator Interrupt Mode (Default): User reading part resets output until next measurement completes. If condition is still true, output is set again at end of next conversion cycle. For example, if a user never reads the part, and temperature goes below T_{LOW} then INT becomes active. It would stay that way until temperature goes above $T_{LOW} + T_{HYST}$. However if the user reads the part, the output would be reset. At the end of the next conversion cycle, if the condition is true, it is set again. If not, it remains reset.

Event Interrupt Mode: User reading part resets output until next condition “event” occurs (in other words, output is only set once for a true condition, if reset by a read, it remains reset until the next triggering threshold has been crossed). Conversely, if a user never read the part, the output would stay set indefinitely after the first event that set the output. An “event” for Event Interrupt Mode is defined as:

1. Transitioning upward across a setpoint, or
2. Transitioning downward across a setpoint’s corresponding hysteresis (after having exceeded that setpoint).

For example, if a user never read the part, and temperature went below T_{LOW} then INT would become active. It would stay that way forever if a user never read the part.

However if the user read the part, the output would be reset. Even if the condition is true, it will remain reset. The temperature must cross above $T_{LOW} + T_{HYST}$ to set the output again.

In either mode, reading any register in the LM92 restarts the conversion. This allows a designer to know exactly when the LM92 begins a comparison. This prevents unnecessary Interrupts just after reprogramming setpoints. Typically, system Interrupt inputs are masked prior to reprogramming trip points. By doing a read just after resetting trip points, but prior to unmasking, unexpected Interrupts are prevented.

Avoid programming setpoints so close that their hysteresis values overlap. An example would be that with a T_{HYST} value of 2 °C then setting T_{HIGH} and T_{LOW} to within 4 °C of each other will violate this restriction. To be more specific, with T_{HYST} set to 2 °C assume T_{HIGH} set to 64 °C. If T_{LOW} is set equal to, or higher than 60 °C this restriction is violated.

1.2 DEFAULT SETTINGS

The LM92 always powers up in a known state. LM92 power up default conditions are:

1. Comparator Interrupt Mode
2. T_{LOW} set to 10 °C
3. T_{HIGH} set to 64 °C
4. T_CRIT set to 80 °C
5. T_{HYST} set to 2 °C
6. INT and T_CRIT_A active low
7. Pointer set to “00”; Temperature Register

The LM92 registers will always reset to these default values when the power supply voltage is brought up from zero volts as the supply crosses the voltage level plotted in the following curve. The LM92 registers will reset again when the power supply drops below the voltage plotted in this curve.

Average Power on Reset Voltage vs Temperature

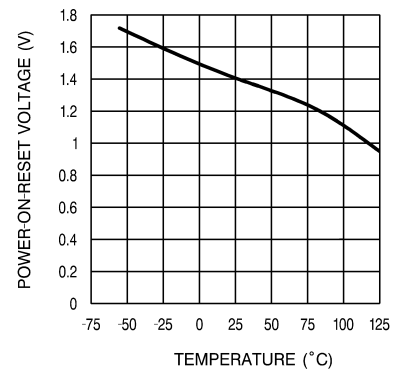

DS101051-18

1.3 SERIAL BUS INTERFACE

The LM92 operates as a slave on the Serial Bus, so the SCL line is an input (no clock is generated by the LM92) and the SDA line is a bi-directional serial data line. According to Serial Bus specifications, the LM92 has a 7-bit slave address. The five most significant bits of the slave address are hard wired inside the LM92 and are “10010”. The two least significant bits of the address are assigned to pins A1–A0, and are set by connecting these pins to ground for a low, (0); or to $+V_S$ for a high, (1).

1.0 Functional Description (Continued)

Therefore, the complete slave address is:

1	0	0	1	0	A1	A0
MSB					LSB	

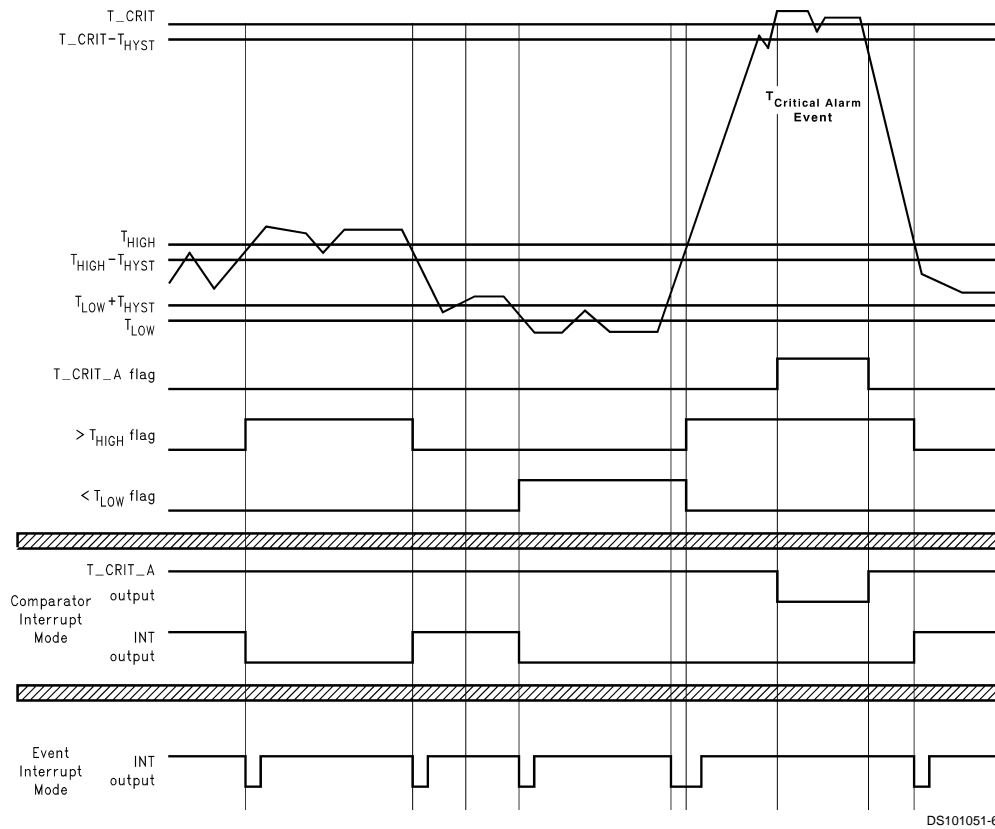

Note: Event Interrupt mode is drawn as if the user is reading the part. If the user doesn't read, the outputs would go low and stay that way until the LM92 is read. Comparator Interrupt Mode is drawn as if the user never reads the part. If the user does read, the outputs will go high once read instruction is executed and, if the fault condition still exists, go low at the end of the next conversion.

FIGURE 3. Temperature Response Diagram

1.4 TEMPERATURE DATA FORMAT

Temperature data can be read from the Temperature and Set Point registers; and written to the Set Point registers. Temperature data can be read at any time, although reading faster than the conversion time of the LM92 will prevent data from being updated. Temperature data is represented by a 13-bit, two's complement word with an LSB (Least Significant Bit) equal to 0.0625 °C:

Temperature	Digital Output	
	Binary	Hex
+130 °C	0 1000 0 010 0000	08 20h
+125 °C	0 0111 1101 0000	07 D0h
+80 °C	0 0101 1010 0000	05 90h
+64 °C	0 0100 0000 0000	04 00h
+25 °C	0 0001 1001 0000	01 90h
+10 °C	0 0000 1010 0000	00 A0h
+2 °C	0 0000 0010 0000	00 20h
+0.0625 °C	0 0000 0000 0001	00 01h
0 °C	00 0000 0000	00 00h
-0.0625 °C	1 1111 1111 1111	1F FFh
-25 °C	1 1110 0111 0000	1E 70h

Temperature	Digital Output	
	Binary	Hex
-55 °C	1 1100 1001 0000	1C 90h

1.5 SHUTDOWN MODE

Shutdown mode is enabled by setting the shutdown bit in the Configuration register via the Serial Bus. Shutdown mode reduces power supply current to 5 µA typical. T_CRIT_A is reset if previously set. Since conversions are stopped during shutdown, T_CRIT_A and INT will not be operational. The Serial Bus interface remains active. Activity on the clock and data lines of the Serial Bus may slightly increase shutdown mode quiescent current. Registers can be read from and written to in shutdown mode. The LM92 takes milliseconds to respond to the shutdown command.

1.6 INT AND T_CRIT_A OUTPUT

The INT and T_CRIT_A outputs are open-drain outputs and do not have internal pull-ups. A "high" level will not be observed on these pins until pull-up current is provided from some external source, typically a pull-up resistor. Choice of resistor value depends on many system factors but, in general, the pull-up resistor should be as large as possible. This will minimize any errors due to internal heating of the LM92.

1.0 Functional Description (Continued)

The maximum resistance of the pull up, based on LM92 specification for High Level Output Current, to provide a 2 volt high level, is 30K ohms.

1.7 FAULT QUEUE

A fault queue of 4 faults is provided to prevent false tripping when the LM92 is used in noisy environments. The 4 faults must occur consecutively to set flags as well as INT and T_CRIT_A outputs. The fault queue is enabled by setting bit 4 of the Configuration Register high (see Section 1.11).

1.8 INTERNAL REGISTER STRUCTURE

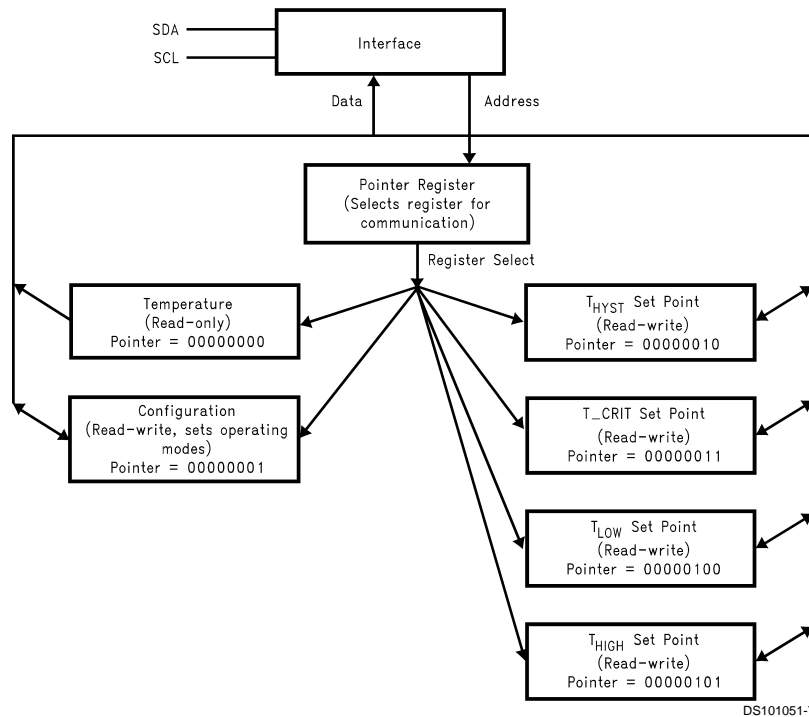

There are four data registers in the LM92, selected by the Pointer register. At power-up the Pointer is set to "00"; the location for the Temperature Register. The Pointer register latches the last location it was set to. In Interrupt Mode, a read from the LM92 resets the INT output. Placing the device in Shutdown mode resets the INT and T_CRIT_A outputs. All registers are read and write, except the Temperature register which is read only.

A write to the LM92 will always include the address byte and the Pointer byte. A write to the Configuration register requires one data byte, while the T_{LOW}, T_{HIGH}, and T_CRIT registers require two data bytes.

Reading the LM92 can take place either of two ways: If the location latched in the Pointer is correct (most of the time it is expected that the Pointer will point to the Temperature register because it will be the data most frequently read from the LM92), then the read can simply consist of an address byte,

followed by retrieving the corresponding number of data bytes. If the Pointer needs to be set, then an address byte, pointer byte, repeat start, and another address byte plus required number of data bytes will accomplish a read.

The first data byte is the most significant byte with most significant bit first, permitting only as much data as necessary to be read to determine the temperature condition. For instance, if the first four bits of the temperature data indicates a critical condition, the host processor could immediately take action to remedy the excessive temperature. At the end of a read, the LM92 can accept either Acknowledge or No Acknowledge from the Master (No Acknowledge is typically used as a signal for the slave that the Master has read its last byte).

An inadvertent 8-bit read from a 16-bit register, with the D7 bit low, can cause the LM92 to stop in a state where the SDA line is held low as shown in *Figure 4*. This can prevent any further bus communication until at least 9 additional clock cycles have occurred. Alternatively, the master can issue clock cycles until SDA goes high, at which time issuing a "Stop" condition will reset the LM92.

1.0 Functional Description (Continued)

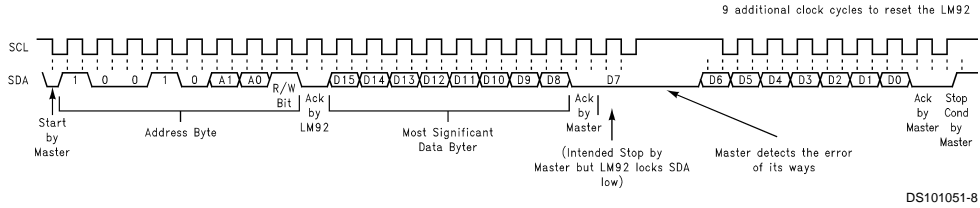

FIGURE 4. Inadvertent 8-Bit Read from 16-Bit Register where D7 is Zero (“0”)

DS101051-8

1.0 Functional Description (Continued)

1.9 POINTER REGISTER

(Selects which registers will be read from or written to):

P7	P6	P5	P4	P3	P2	P1	P0
0	0	0	0	0	Register Select		

P0–P2: Register Select:

P2	P1	P0	Register
0	0	0	Temperature (Read only) (Power-up default)
0	0	1	Configuration (Read/Write)
0	1	0	T _{HYST} (Read/Write)
0	1	1	T _{CRIT} (Read/Write)
1	0	0	T _{LOW} (Read/Write)
1	0	1	T _{HIGH} (Read/Write)
1	1	1	Manufacturer's ID

P3–P7: Must be kept zero.

1.10 TEMPERATURE REGISTER

(Read Only):

D15	D14	D13	D12	D11	D10	D9	D8	D7	D6	D5	D4	D3	D2	D1	D0
Sign	MSB	Bit 10	Bit 9	Bit 8	Bit 7	Bit 6	Bit 5	Bit 4	Bit 3	Bit 2	Bit 1	Bit 0	CRIT	HIGH	LOW
													Status Bits		

D0–D2: Status Bits

D3–D15: Temperature Data. One LSB = 0.0625°C. Two's complement format.

1.11 CONFIGURATION REGISTER

(Read/Write):

D7	D6	D5	D4	D3	D2	D1	D0
0	0	0	Fault Queue	INT Polarity	T _{CRIT_A} Polarity	INT Mode	Shutdown

D0: Shutdown - When set to 1 the LM92 goes to low power shutdown mode. Power up default of "0".

D1: Interrupt mode - 0 is Comparator Interrupt mode, 1 is Event Interrupt mode. Power up default of "0".

D2, D3: T_{CRIT_A} and INT Polarity - 0 is active low, 1 is active high. Outputs are open-drain. Power up default of "0"

D4: Fault Queue - When set to 1 the Fault Queue is enabled, see *Section 1.7*. Power up default of "0".

D5–D7: These bits are used for production testing and must be kept zero for normal operation.

1.12 T_{HYST}, T_{LOW}, T_{HIGH} AND T_{CRIT_A} REGISTERS

(Read/Write):

D15	D14	D13	D12	D11	D10	D9	D8	D7	D6	D5	D4	D3	D2	D1	D0
Sign	MSB	Bit 10	Bit 9	Bit 8	Bit 7	Bit 6	Bit 5	Bit 4	Bit 3	Bit 2	Bit 1	Bit 0	X	X	X

D0–D2: Undefined

D3–D15: T_{HYST}, T_{LOW}, T_{HIGH} or T_{CRIT} Trip Temperature Data. Power up default is T_{LOW} = 10°C, T_{HIGH} = 64°C, T_{CRIT} = 80°C, T_{HYST} = 2°C.

T_{HYST} is subtracted from T_{HIGH}, and T_{CRIT}, and added to T_{LOW}.

Avoid programming setpoints so close that their hysteresis values overlap. See *Section 1.1*.

1.0 Functional Description (Continued)

1.13 Manufacturer's Identification Register

(Read only):

D15	D14	D13	D12	D11	D10	D9	D8	D7	D6	D5	D4	D3	D2	D1	D0
1	0	0	0	0	0	0	0	0	0	0	0	0	0	0	1

D0–D15: Manufactures ID.

2.0 I²C Timing Diagrams

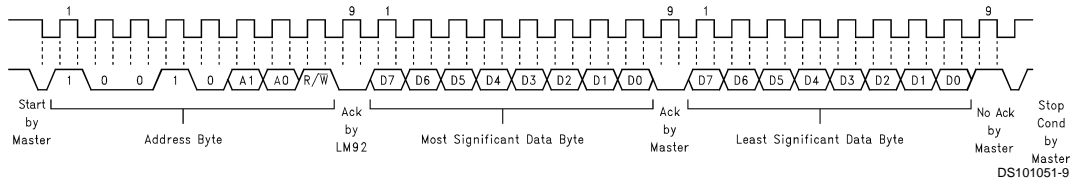

Typical 2-Byte Read From Preset Pointer Location Such as Temp or Comparison Registers

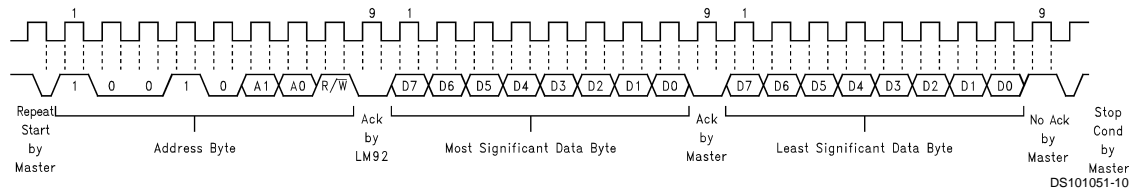
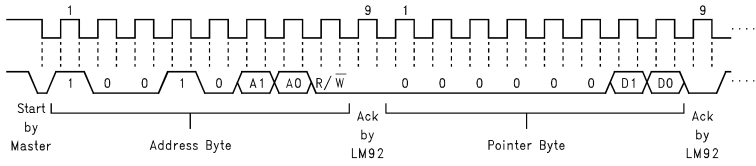

Typical Pointer Set Followed by Immediate Read for 2-Byte Register such as Temp or Comparison Registers

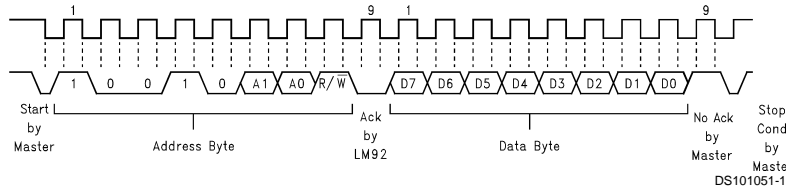

Typical 1-Byte Read from Configuration Register with Preset Pointer

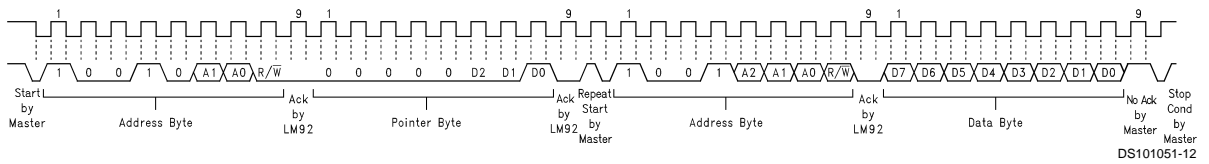

Typical Pointer Set Followed by Immediate Read from Configuration Register

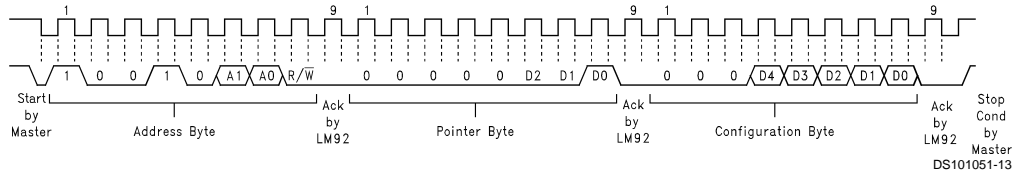

Configuration Register Write

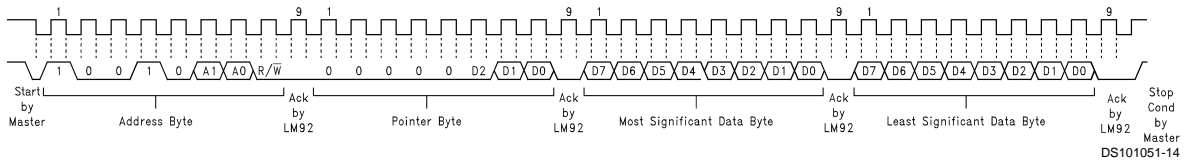

Comparison Register Write

FIGURE 6. Timing Diagrams

3.0 Application Hints

The temperature response graph in *Figure 7* depicts a typical application designed to meet ACPI requirements. In this type of application, the temperature scale is given an arbitrary value of "granularity", or the window within which temperature notification events should occur. The LM92 can be programmed to the window size chosen by the designer, and will issue interrupts to the processor whenever the window limits have been crossed. The internal flags permit quick determination of whether the temperature is rising or falling.

The T_CRIT limit would typically use its separate output to activate hardware shutdown circuitry separate from the processor. This is done because it is expected that if temperature has gotten this high that the processor may not be responding. The separate circuitry can then shut down the system, usually by shutting down the power supply.

Note that the INT and T_CRIT_A outputs are separate, but can be wire-or'd together. Alternatively the T_CRIT_A can be diode or'd to the INT line in such a way that a T_CRIT_A event activates the INT line, but an INT event does not activate the T_CRIT_A line. This may be useful in the event that it is desirable to notify both the processor and separate T_CRIT_A shutdown circuitry of a critical temperature alarm at the same time (maybe the processor is still working and can coordinate a graceful shutdown with the separate shutdown circuit).

To implement ACPI compatible sensing it is necessary to sense whenever the temperature goes outside the window, issue an interrupt, service the interrupt, and reprogram the window according to the desired granularity of the temperature scale. The reprogrammed window will now have the current temperature inside it, ready to issue an interrupt whenever the temperature deviates from the current window.

To understand this graph, assume that at the left hand side the system is at some nominal temperature. For the 1st event temperature rises above the upper window limit, T_{HIGH} , causing INT to go active. The system responds to the interrupt by querying the LM92's status bits and determines that T_{HIGH} was exceeded, indicating that temperature is rising. The system then reprograms the temperature limits to a value higher by an amount equal to the desired granularity. Note that in Event Interrupt Mode, reprogramming the limits has caused a second, known, interrupt to be issued since temperature has been returned within the window. In Comparator Interrupt Mode, the LM92 simply stops issuing interrupts.

The 2nd event is another identical rise in temperature. The 3rd event is typical of a drop in temperature. This is one of the conditions that demonstrates the power of the LM92, as the user receives notification that a lower limit is exceeded in such a way that temperature is dropping.

The Critical Alarm Event activates the separate T_CRIT_A output. Typically, this would feed circuitry separate from the processor on the assumption that if the system reached this temperature, the processor might not be responding.

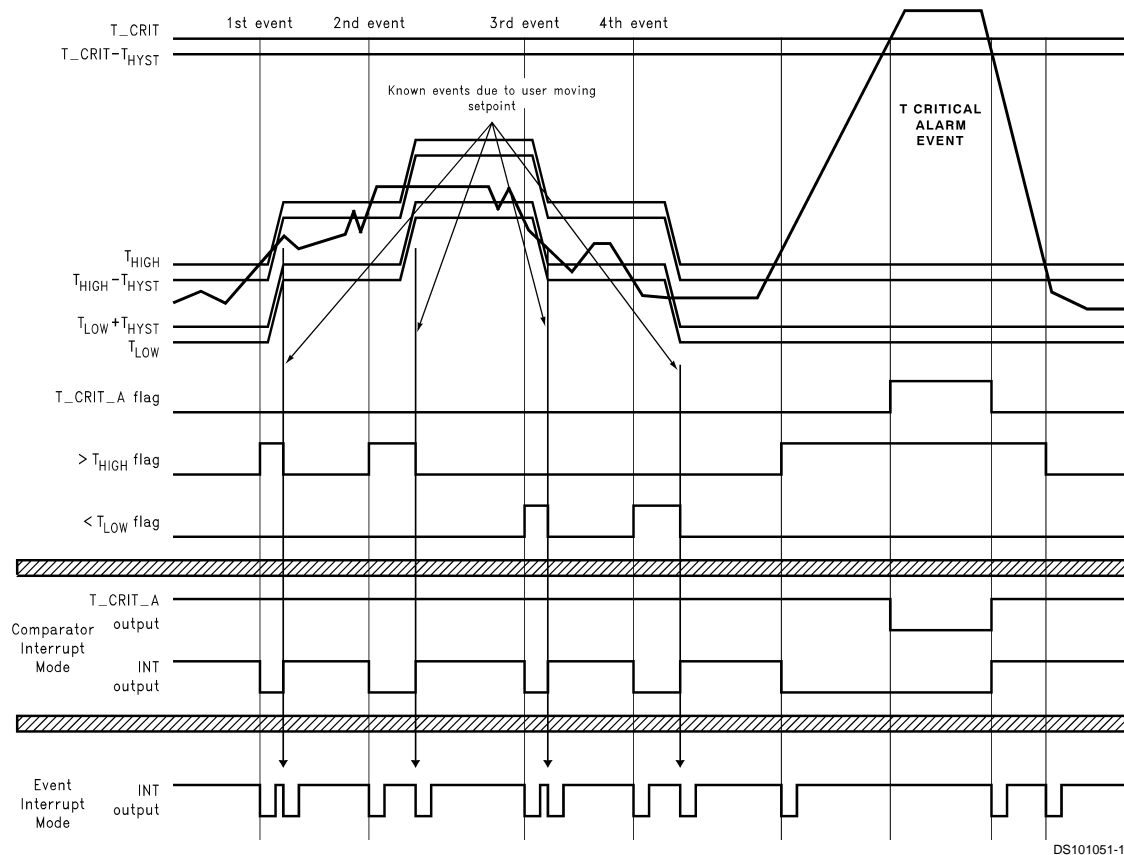

Note: Event Interrupt mode is drawn as if the user is reading the part. If the user doesn't read, the outputs would go low and stay that way until the LM92 is read.

FIGURE 7. Temperature Response Diagram for ACPI Implementation

4.0 Typical Applications

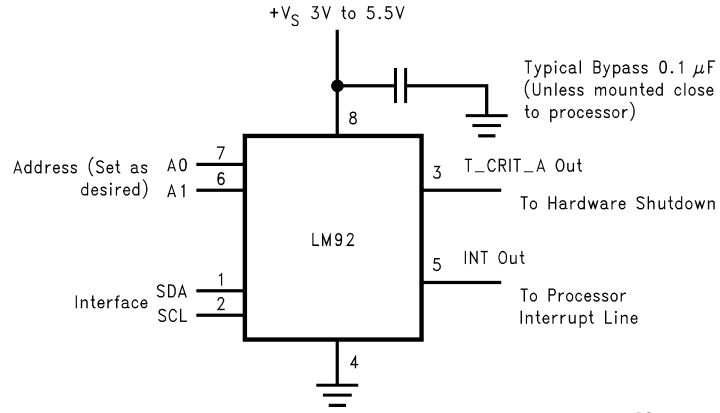

DS101051-16

FIGURE 8. Typical Application

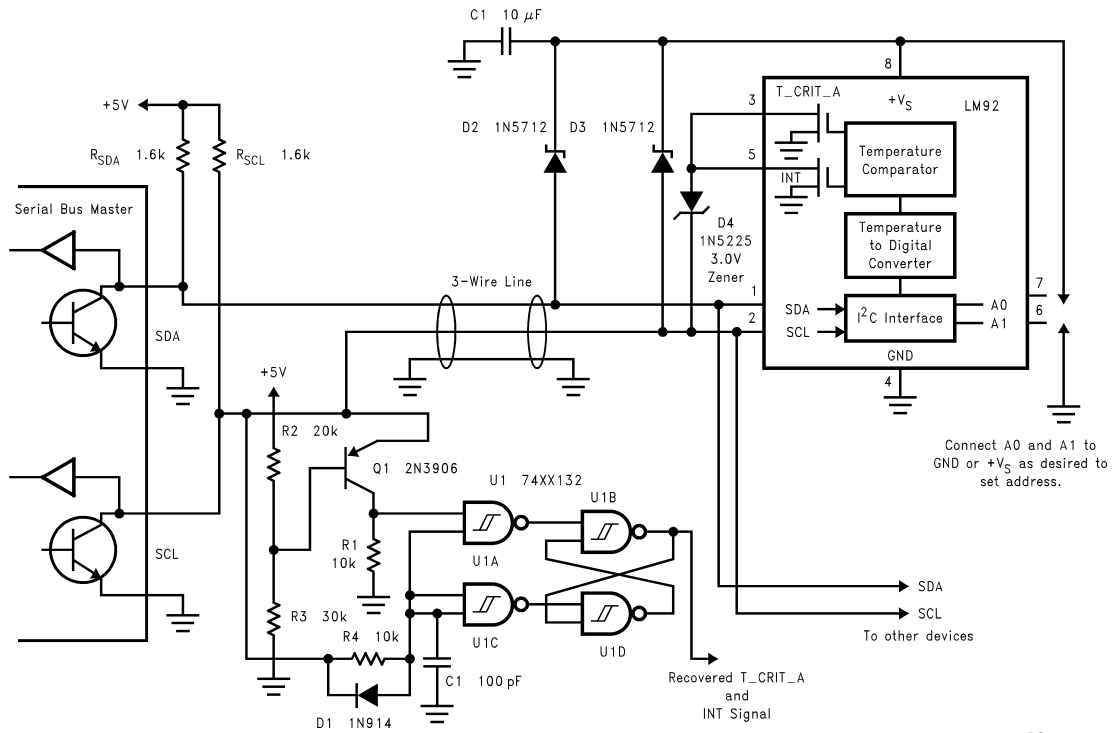

DS101051-17

FIGURE 9. Remote HVAC temperature sensor communicates via 3 wires, including thermostat signals.

4.0 Typical Applications (Continued)

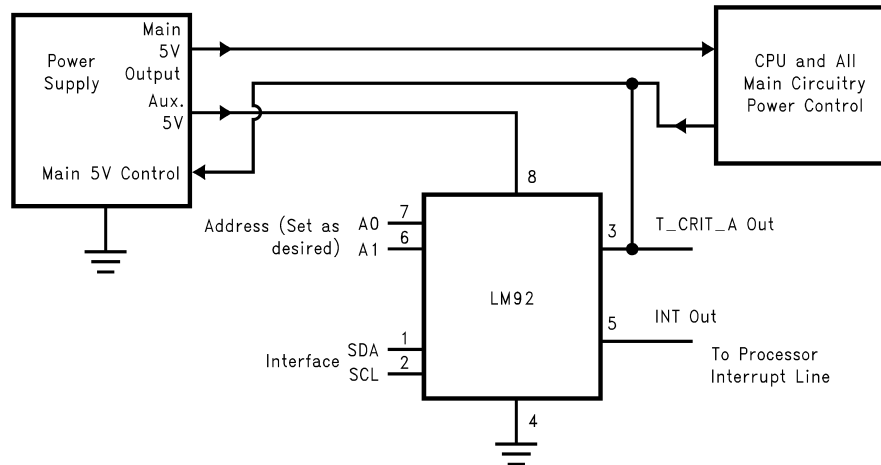

DS101051-19

FIGURE 10. ACPI Compatible Terminal Alarm Shutdown. By powering the LM92 from auxiliary output of the power supply, a non-functioning overheated computer can be powered down to preserve as much of the system as possible.

Physical Dimensions inches (millimeters) unless otherwise noted

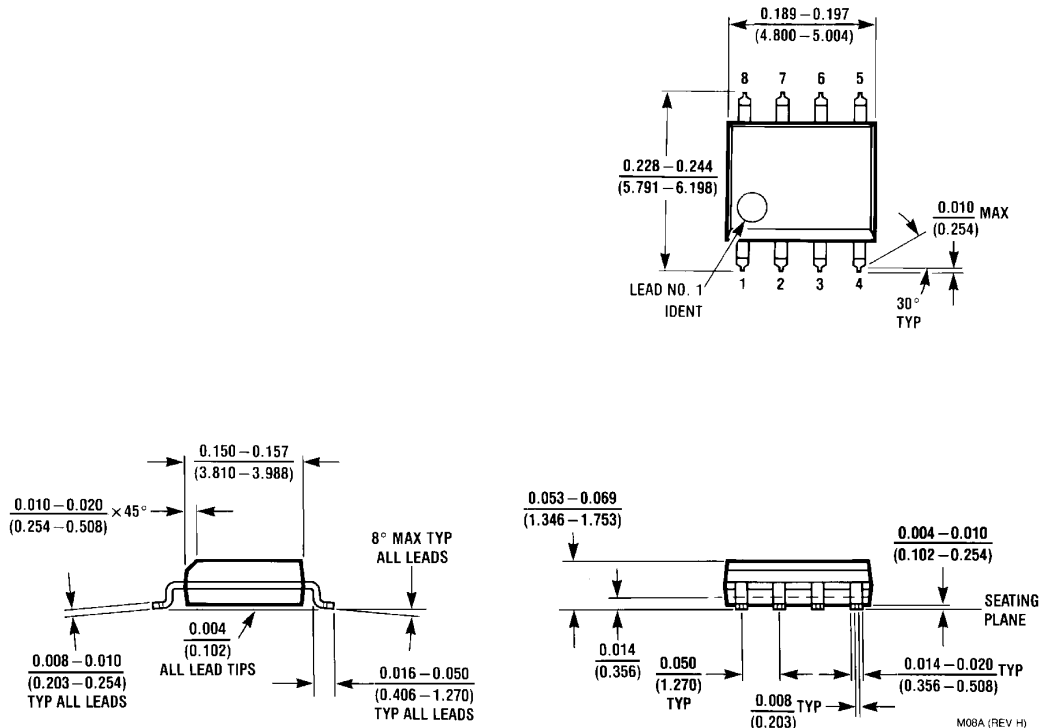

**8-Lead (0.150" Wide) Molded Small Outline Package (SOP), JEDEC
 Order Number LM92CIM or LM92CIMX
 NS Package Number M08A**

LIFE SUPPORT POLICY

NATIONAL'S PRODUCTS ARE NOT AUTHORIZED FOR USE AS CRITICAL COMPONENTS IN LIFE SUPPORT DEVICES OR SYSTEMS WITHOUT THE EXPRESS WRITTEN APPROVAL OF THE PRESIDENT AND GENERAL COUNSEL OF NATIONAL SEMICONDUCTOR CORPORATION. As used herein:

1. Life support devices or systems are devices or systems which, (a) are intended for surgical implant into the body, or (b) support or sustain life, and whose failure to perform when properly used in accordance with instructions for use provided in the labeling, can be reasonably expected to result in a significant injury to the user.
2. A critical component is any component of a life support device or system whose failure to perform can be reasonably expected to cause the failure of the life support device or system, or to affect its safety or effectiveness.



National Semiconductor Corporation
 Americas
 Tel: 1-800-272-9959
 Fax: 1-800-737-7018
 Email: support@nsc.com
 www.national.com

National Semiconductor Europe
 Fax: +49 (0) 180-530 85 86
 Email: europe.support@nsc.com
 Deutsch Tel: +49 (0) 69 9508 6208
 English Tel: +44 (0) 870 24 0 2171
 Français Tel: +33 (0) 1 41 91 8790

National Semiconductor Asia Pacific Customer Response Group
 Tel: 65-2544466
 Fax: 65-2504466
 Email: ap.support@nsc.com

National Semiconductor Japan Ltd.
 Tel: 81-3-5639-7560
 Fax: 81-3-5639-7507